

# 495HR Padlocks

You will receive:

## Full Credit:

- Acceptable part number.
- Fully assembled and complete. **\*\*Ask the service department or customer for the reason why the component was replaced.**
- No non-operational damage such as excessive rust, corrosion, mishandling, torch marks, or fire damage.

## Partial Credit:

- Non-operational damage on one of the two pieces (mishandling, excessive rust, corrosion, torch marks or pitting).

## No Core Refund:

- Unacceptable part number (ex. CAT Classic or non-Caterpillar part).
- Non-operational damage on both pieces (mishandling, excessive rust, corrosion, torch marks or pitting).
- Fire damage.
- Disassembled or not complete.
- Unsuccessful attempt to salvage.

# Air Compressors

You will receive:

## Full Credit:

- Acceptable part number.
- Fully assembled and complete. Non failed, running core.  
**\*\*Ask the service department or customer for the reason why the component was replaced.**
- No non-operational damage such as excessive rust, corrosion, mishandling, torch marks, or fire damage.
- Must be returned in the packaging that was provided.
- Component not visibly cracked, broken or welded.
- Drive gear mounting nut or bolt must easily thread on.

## Partial Credit:

- Non-operational damage (mishandling, excessive rust, corrosion, torch marks or pitting).
- One or two major parts damaged. See list of major parts below.

## No Core Refund:

- Unacceptable part number (ex. CAT Classic or non-Caterpillar part).
- Disassembled or not complete.
- Fire damage.
- Unsuccessful attempt to salvage.

# Alternator

You will receive:

## Full Credit:

- Acceptable part number.  
Fully assembled and complete. **\*\*Ask the service department or customer for the reason why the component was replaced.**
- No non-operational damage such as excessive rust, corrosion, mishandling, torch marks, or fire damage.
- Not cracked or damaged.

## Partial Credit:

- Housing or shaft cracked or damaged.
- Non-operational damage such as excessive rust, corrosion, or pitting.

## No Core Refund:

- Unacceptable part number (ex. CAT Classic or non-Caterpillar part).
- Disassembled.
- Fire damage.
- Unsuccessful attempt to salvage.

## Axle Groups

You will receive:

### Full Credit:

- Acceptable part number.  
Fully assembled and complete. Non failed, running core. **\*\*Ask the service department or customer for the reason why the component was replaced.**
- No non-operational damage such as excessive rust, corrosion, mishandling, torch marks, or fire damage.
- Must be returned on stand that was provided.
- Case, housings, and trunnion support arms (oscillating axle only) not visibly cracked, broken, or welded.

### Partial Credit:

- Case, housings, or trunnion support arms (oscillating axle only) visibly cracked, broken, or welded.
- Failed, non-running core.
- Non-operational damage (such as mishandling, excessive rust, corrosion, pitting, or torch marks).

### No Core Refund:

- Unacceptable part number (ex. CAT Classic or non-Caterpillar part).
- Disassembled or not complete.
- Fire damage.
- Unsuccessful attempt to salvage.

# Brake Groups

You will receive:

## Full Credit:

- Acceptable part number.
- Not visibly cracked, broken, bent, or welded.  
Fully assembled and complete. **\*\*Ask the service department or customer for the reason why the component was replaced.**
- No non-operational damage such as excessive rust, corrosion, mishandling, torch marks, or fire damage.
- Must be returned on stand that was provided (if applicable)

## Partial Credit:

- Acceptable part number
- Visibly cracked, broken, bent, or welded.
- Non-operational damage (excessive rust, mishandling).

## No Core Refund:

- Unacceptable part number (ex. CAT Classic or non-Caterpillar part).
- Disassembled.
- Visibly cracked, broken, or bent.
- Non-operational damage (Fire damage, unsuccessful attempt to salvage, welding – see Figure 2)



**Figure 1** **Full Core Refund**  
Fully assembled and complete

# Circle Drive

You will receive:

## Full Credit:

- Acceptable part number - Caterpillar® part
- Fully assembled, non-failed, running core. **\*\*Ask the service department or customer for the reason why the component was replaced.**
- No visible cracks, breaks or welds
- No visible breakage or rust on the gears, worms and pinions
- Component without known internal damage
- No non-operational damage such as excessive rust, corrosion, mishandling, torch marks, fire damage or damage from improper packaging

## Partial Credit:

- Acceptable part number - Caterpillar® part
- Failed non-running core
- Cracked, broken, welds visible on the case, pinion, cover
- Visible breakage or rust on the gears
- Reducers with known internal damage
- Non-operational damage such as excessive rust, corrosion, mishandling, torch marks, fire damage or damage from improper packaging

## No Core Refund:

- Unacceptable part number (ex. CAT Classic or non-Caterpillar part).
- Disassembled or not complete.
- Fire damage.
- Unsuccessful attempt to salvage.
- Housing, pulley, or gear is cracked, broken, or welded

# Cylinder Head

You will receive:

## Full Credit:

- Acceptable part number.
- Fully assembled and complete. Non failed, running core.  
**\*\*Ask the service department or customer for the reason why the component was replaced.**
- No non-operational damage such as excessive rust, corrosion, mishandling, torch marks, or fire damage.
- Must be returned on stand that was provided if applicable.
- Casting is not visibly cracked, broken, or have severe damage (minor damage such as small dents, light scratches, pitting, and minor gouges are acceptable).
- Casting is not welded by source other than Caterpillar.

## Partial Credit:

- Casting is visibly cracked, has severe damage or metal stamp marks in machined surfaces.
- Casting is welded by source other than Caterpillar.
- Failed, non-running core.
- Non-operational damage (mishandling, excessive rust, corrosion, torch marks or pitting).

## No Core Refund:

- Unacceptable part number (ex. CAT Classic or non-Caterpillar part).
- Disassembled or not complete.
- Fire damage.
- Unsuccessful attempt to salvage.



# Differentials

You will receive:

## Full Credit:

- Acceptable part number.
- Fully assembled and complete. Non failed, running core. Must pass rotation check. Rotate pinion shaft twice clockwise and twice counter clockwise.  
**\*\*Ask the service department or customer for the reason why the component was replaced.**
- No non-operational damage such as excessive rust, corrosion, mishandling, torch marks, or fire damage.
- Must be returned on stand that was provided.
- Differential, spider gears, or housing not visibly cracked or broken.  
\*\*\*Ring and pinion gear wear and damage is acceptable as Level 1.

## Partial Credit:

- Failed non-running core.
- Differential, spider gears, or housing visibly cracked or broken.
- Non- operational damage such as excessive rust, corrosion, mishandling, or torch marks)

## No Core Refund:

- Unacceptable part number (ex. CAT Classic or non-Caterpillar part).
- Disassembled or not complete.
- Fire damage.
- Unsuccessful attempt to salvage.

# Dipper Link Assembly

You will receive:

## Full Credit:

- Acceptable part number.
- Not visibly cracked, broken, bent, or welded.
- No operational damage (example: nicks, gouges, grooving, or pitting on cushion surfaces or on link assembly) **\*\*Inspection Tip: Ask customer or service department for reason of replacement.**
- No non-operational damage such as excessive rust, corrosion, mishandling, torch marks, or fire damage.
- Must be returned on stand that was provided.

## Partial Credit:

- Acceptable part number
- Operational damage (example: nicks, gouges, grooving, or pitting on cushion surface or on link assembly– see Figure 1).
- Non-operational damage (excessive rust).

## No Core Refund:

- Unacceptable part number (ex. CAT Classic or non-Caterpillar part).
- Disassembled.
- Visibly cracked, broken, or bent.
- Non-operational damage (Fire damage, unsuccessful attempt to salvage, welding – see Figure 2)

## Add Charge:

- Core not delivered on proper metal stand



*Figure 1 – There is evidence of pitting marks behind the normal wear surface of the link. This would be considered operational damage and would result in a partial credit.*



*Figure 2 – The surface of the link has been welded and would be an example of an unsuccessful attempt to salvage, resulting in no core refund.*

# Engine Oil Pumps

You will receive:

## Full Credit:

- Acceptable part number.
- Fully assembled and complete. Non failed, running core.  
**\*\*Ask the service department or customer for the reason why the component was replaced.**
- No non-operational damage such as excessive rust, corrosion, mishandling, torch marks, pitting, or fire damage.
- No cracked or broken housings

## No Core Refund:

- Unacceptable part number (ex. CAT Classic or non-Caterpillar part).
- Non-operational damage (such as excessive rust, corrosion, mishandling, torch marks, pitting, or fire damage).
- Not fully assembled or complete (missing springs or retainers).
- Unsuccessful attempt to salvage.

## Add Charge:

- Applied for housing that is cracked or broken
- Applied for each spring or retainer that is missing (refer to figure 4).



**Figure 1** Full Core Refund  
Fully assembled and complete



**Figure 2** Full Core Refund  
Fully assembled and complete



**Figure 3** Full Core Refund  
Fully assembled and complete



**Figure 4** Core Refund Less Add Charge  
Missing retainer and spring



**Figure 5** No Core Refund  
Example of unacceptable Caterpillar part

# Engines: 3500 & C175 Series

You will receive:

## Full Credit:

- Acceptable part number.
- Fully assembled and complete. Non failed, running core.  
**\*\*\*Inspection Tip: Ask customer or service department for reason of replacement.**
- No non-operational damage such as excessive rust, corrosion, mishandling, torch marks, or fire damage.
- Must be returned on stand that was provided.
- Cylinder block is not visibly cracked, broken, or welded
- The crankshaft must rotate through 360 degrees twice in one direction and once in the opposite direction.  
*\*\*This must be performed after the engine has been removed from the machine.*

## Partial Credit:

- Crankshaft will not rotate through 360 degrees twice in one direction and once in the opposite direction.
- Known internal damage (i.e. dropped valves or spun bearings).
- Non-operational damage (mishandling, excessive rust, corrosion, or pitting)
- Failed, non-running core.

## No Core Refund:

- Unacceptable part number (ex. CAT Classic or non-Caterpillar part).
- Disassembled or not complete.
- Fire damage.
- Unsuccessful attempt to salvage.

**Add Charge:**

- Cylinder block visibly cracked or broken. This is a separate charge on core return.
- Fluids not properly drained.
- Not returned on component specific stand.
- Upper End Failures: Engines found to have Upper End Failure (i.e., cylinder head not salvageable) will receive full credit but will be assessed an Add Charge per damaged cylinder. An Add Charge for Upper End Failure will be administered to all cylinder(s) even if contingent from initial failing cylinder. No additional charge will be assessed for contingent damage to other components (turbo, lifter, injectors, etc.) from an upper end failure.
- Core Credit and additional charges will be subject to change based on findings at Toromont Remanufacturing during inspection.

**Inspection tips:**

- **Fully assembled and complete:** Engines which appear to have salvageable parts removed from them and had non-salvageable parts substituted in their place will be subject to a detailed inspection. If a returned core is found to have been scavenged or assembled from scrap material, the core will be rejected and the customer will be assessed a \$250.00 inspection fee.
- **Preparing For Shipment:** Please ensure that all oil and fluids are drained prior to shipment and the engine is securely fastened to its metal shipping stand. Failure to do so could result in fines from the Ministry of Transport or result in Health and Safety concerns.
- **Crankshaft Rotation:** After the engine has been removed from the machine, rotate the crankshaft through 360 degrees twice in one direction and once in the opposite direction using the 9S9082 crankshaft turning tool. Listen for internal damage while performing the inspection. If you hear internal damage or know there is internal damage from moving the machine prior to removal, the core will be considered for Partial Credit and an add bill must be charged to the customer.

If the cylinder block is equipped with sound suppression panels, the panels should be examined for signs of a broken block, such as dents on the outside of the panels or oil leaks from behind the panels.

Engines which have been disassembled (i.e. loosened main or rod caps or bearings removed) to ensure the crankshaft rotates freely will be subject to Partial Credit add bill.



Figure 1 Full Core Refund  
Fully assembled and correctly fastened to metal stand



Figure 2 Full Core Refund  
Engine with rear mounts and modified stand



Figure 3 Damaged Core Refund  
Broken engine block

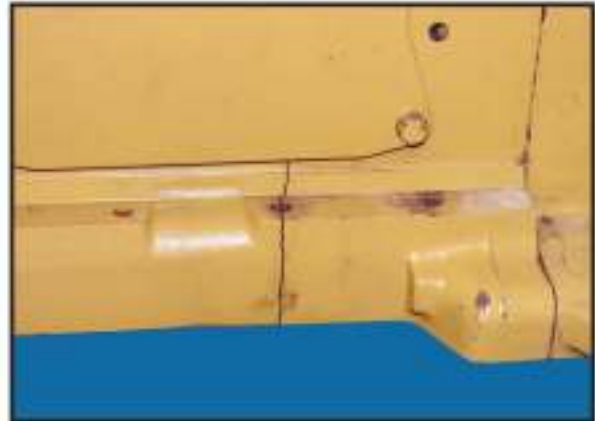


Figure 4 Add Charge  
Cracked block



Figure 5 Add Charge  
Core not returned on correct stand



Figure 6 Add Charge  
Upper end failure – damaged cylinder head



# Engines

You will receive:

## Full Credit:

- Acceptable part number.  
Fully assembled and complete. Non failed, running core. **\*\*Ask the service department or customer for the reason why the component was replaced.**
- No non-operational damage such as excessive rust, corrosion, mishandling, torch marks, or fire damage.
- Must be returned on stand that was provided.
- Cylinder block is not visibly cracked, broken, or welded
- The crankshaft must rotate through 360 degrees twice in one direction and once in the opposite direction. **\*\*This must be performed after the engine has been removed from the machine.**

## Partial Credit:

- Crankshaft will not rotate through 360 degrees twice in one direction and once in the opposite direction.
- Known internal damage (i.e. dropped valves or spun bearings).
- Non-operational damage (mishandling, excessive rust, corrosion, or pitting)
- Failed, non-running core.

## No Core Refund:

- Unacceptable part number (ex. CAT Classic or non-Caterpillar part).
- Disassembled or not complete.
- Fire damage.
- Unsuccessful attempt to salvage.

**Add Charge:**

- Cylinder block visibly cracked or broken. This is a separate charge on core return. \*\*\*See “Misc Item Charge” in core credit screen.

**Inspection tips:**

- **Fully assembled and complete:** Engines which appear to have salvageable parts removed from them and had non-salvageable parts substituted in their place will be subject to a detailed inspection. If a returned core is found to have been scavenged or assembled from scrap material, the core will be rejected and the customer will be assessed a \$250.00 inspection fee.
- **Preparing For Shipment:** Please ensure that all oil and fluids are drained prior to shipment and the engine is securely fastened to its metal shipping stand. Failure to do so could result in fines from the Ministry of Transport or result in Health and Safety concerns.
- **Crankshaft Rotation:** After the engine has been removed from the machine, rotate the crankshaft through 360 degrees twice in one direction and once in the opposite direction using approximately a 2 ft. Johnson bar. Listen for internal damage while performing the inspection. If you hear internal damage or know there is internal damage from moving the machine prior to removal, the core will be considered for PARTIAL CREDIT and an add bill must be charged to the customer.

If the cylinder block is equipped with sound suppression panels, the panels should be examined for signs of a broken block, such as dents on the outside of the panels or oil leaks from behind the panels.

Engines which have been disassembled (i.e. loosened main or rod caps or bearings removed) to ensure the crankshaft rotates freely will be subject to PARTIAL CREDIT add bill.

# Final Drives

You will receive:

## Full Credit:

- Acceptable part number.
- Fully assembled and complete. Non failed, running core. **\*\*Ask the service department or customer for the reason why the component was replaced.**  
Perform rotation test on component. Must rotate twice clockwise, and twice counter clockwise.
- No non-operational damage such as excessive rust, corrosion, mishandling, torch marks, or fire damage.
- Must be returned on stand that was provided.
- Wheel hub, carrier or spindle not visibly cracked or broken.
- Gears not visibly broken or rusted (with cover plate removed).
- 785 & 789 rear final drive must have cast wheel, not wrapper band wheel.

## Partial Credit:

- Failed non-running core.
- Non-operational damage (mishandling, excessive rust, corrosion, or pitting)
- Wheel hub, carrier, gears, or spindle is visibly cracked, broken, welded.
  - Visibly cracked spindle (meaning below the flange, anything above the flange is not chargeable).
- 785 & 789 rear final drive that is wrapper band version.

## No Core Refund:

- Unacceptable part number (ex. CAT Classic or non-Caterpillar part).
- Disassembled or not complete.
- Fire damage.
- Unsuccessful attempt to salvage.

**Add Charge:**

- Damages to spindles that result in scoring, pitting or cracks are subject to additional charges after internal inspection.
- Core not delivered on proper metal stand
- Oil and fluids not drained prior to shipping.

**Inspection Tips:**

- Full vs. Damaged Core Refund: To receive a Full Core Refund, the final drive or swing drive must be a non-failed “running core”. The major components including the wheel hub, carrier, spindle, or pinion gear must not be damaged or broken.
- The customer must be informed at the time of sale that a partial core credit will apply for damage or broken major components. \*\*\*OUT BOARD COVER MUST BE REMOVED AND REPLACED FOR INSPECTION OF INTERNAL GEARS.
- Shipping Stand: All final drive cores must be returned securely fastened to the metal stand that the part was shipped on. Cores not returned on this stand are subject to an add charge.
- Drain Oil: Drain all oil from cores. Seal all openings with plugs and covers prior to shipping.

# Front Suspension Group

You will receive:

## Full Credit:

Acceptable part number. **\*\*Ask the service department or customer for the reason why the component was replaced.**

- Not visibly cracked, broken, bent, or welded. Spider web-type cracking that is commonly seen on the chromed surface of the rod is allowable for Full Core Refund (see Figure 1).
- No operational damage (example: nicks, gouges, grooving, or pitting on rod or internal surface on housing – see Figures 4-7).
- No non-operational damage such as excessive rust, corrosion, mishandling, torch marks, or fire damage.
- Must be returned on stand that was provided.

## Partial Credit:

- Acceptable part number
- Operational damage (example: nicks, gouges, grooving, or pitting on rod or internal surface on housing – see Figures 4-7).
- Non-operational damage (excessive rust – see Figure 3).

## No Core Refund:

- Unacceptable part number (ex. CAT Classic or non-Caterpillar part).
- Rod visibly cracked (see Figure 2)
- Broken or bent.
- Non-operational damage (unsuccessful attempt to salvage or mishandling – see Figure 10).



Figure 1: Spider web cracking on rod chromed surface.

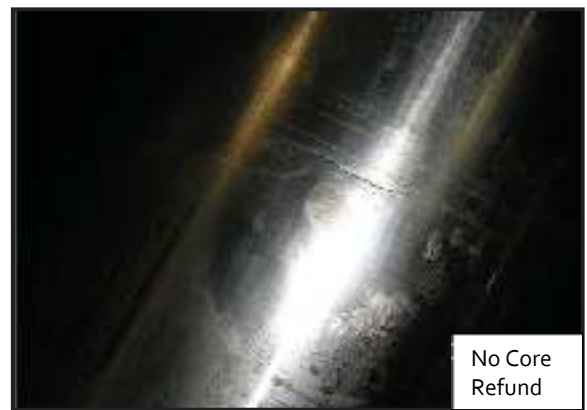


Figure 2 – Rod visibly cracked.



Figure 3 – Excessive rust



Figure 4 – Operational wear



Figure 5 - Gouging



Figure 6 - Grooving

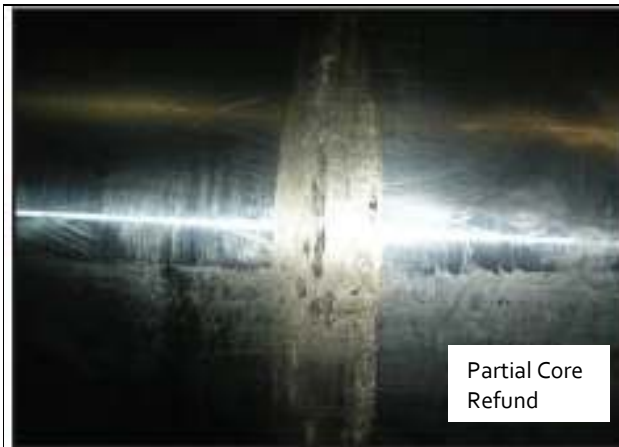


Figure 7 - Pitting



Figure 8 - Not visibly cracked or broken



Figure 9 - Visibly cracked or broken



Figure 10 - Mishandled

## Inspection Tips

**Operational Damage:** This core acceptance criterion is structured to promote a repair-before-failure philosophy. If properly maintained and monitored, cores may oftentimes be salvaged with less expensive salvage operations.

When cores have been worn to the point where more extensive and expensive salvage operations such as laser cladding are required, they will only qualify for a Damaged Core Refund. Examples of excessive operational damage include pitting/gouging of the chromed surface or significant grooving caused by contamination or seal failures.

**Non-operational Damage:** Non-operational damage is often caused from improper handling (ex. hammer damage) or improper storage.

**Unsuccessful Attempt to Salvage:** Customers are allowed to buff grind a chrome

crack area to determine if the rod chrome crack has migrated into the parent material of the rod assembly. If the customer chooses not to salvage the rod and then returns it to Reman, it will be treated as an unsuccessful attempt to salvage and qualify at most for a Partial Core Refund.

**Rust or Corrosion:** If rust can be wiped away with an emery cloth, the core can be accepted for Full Core Refund. Excessive rust, which is usually caused by incorrect storage, will result in a Partial Core Refund. Package cores in the original container and store in a method that will prevent any moisture exposure. Rods will be given a Partial Core Refund if excessive rust, pitting, and/or corrosion are present.



# Fuel Systems & Fuel Pumps

You will receive:

## Full Credit:

- Acceptable part number.
- Fully assembled and complete. Non failed, running core. **\*\*Ask the service department or customer for the reason why the component was replaced.**
- No non-operational damage such as excessive rust, corrosion, mishandling, torch marks, or fire damage.
- Must be returned in the packaging that was provided.
- Housing, pulley, or gear not cracked, broken, or welded.

## Partial Credit:

- Non-operational damage (mishandling, excessive rust, corrosion, torch marks or pitting).
- Failed Core.

## No Core Refund:

- Unacceptable part number (ex. CAT Classic or non-Caterpillar part).
- Disassembled or not complete.
- Fire damage.
- Unsuccessful attempt to salvage.
- Housing, pulley, or gear is cracked, broken, or welded

**Inspection Tips:**

**Full Core Refund**



*Figure 1: Fully assembled and complete*



*Figure 2: Common rail fuel pump*

**No Core Refund**



*Figure 3: Broken housing*



*Figure 4: Shaft bearing failure*

# Hydraulic Cylinder Group

You will receive:

## Full Credit:

- Acceptable part number.
- Fully assembled and complete. Non failed, running core. **\*\*Ask the service department or customer for the reason why the component was replaced.**
- No non-operational damage such as excessive rust, corrosion, mishandling, torch marks, or fire damage.
- Must be returned on stand that was provided.
- Tube not visibly damaged on the outside.
- Both eyes and trunnion are not visibly cracked or broken.
- Rod is not visibly bent. Bend must be within specifications outlined in [SEBF8072](#).

## Partial Credit:

- Ruptured tube/barrel.
- Non-operational damage (mishandling, excessive rust, corrosion, or pitting)
- Rod eye OR barrel eye cracked or broken.
- Head damaged.
- Rod cracked, broken or visibly bent. Bend must be within specifications outlined in [SEBF8072](#).
- Failed, non-running core.

## No Core Refund:

- Unacceptable part number (ex. CAT Classic or non-Caterpillar part).
- Disassembled or not complete.
- Fire damage.
- Unsuccessful attempt to salvage.

- Rod eye AND barrel eye are cracked or broken.

**Add Charge:**

- Internal damages that result in scoring/pitting from contamination or bent rods are subject to additional charges after further inspection at Toromont Remanufacturing facility
- Core not delivered on proper metal stand
- Oil and fluids not drained prior to shipping.

**Inspection Tips:**

- Rod Straightness Inspection: the full length of the rod must be able to slide into the barrel.
- Preparing for Shipment: Please ensure that all oil and fluids are drained prior to shipment and the barrel is securely fastened to a proper skid. Failure to do so could result in fines from the Ministry of Transport or result in Health and Safety concerns.

# Hydraulic Pumps & Motors

You will receive:

## Full Credit:

- Acceptable part number.
- Fully assembled and complete. Non failed, running core. Inspection Tip: Rotate shaft twice in one direction and once in other direction. **\*\*Ask the service department or customer for the reason why the component was replaced.**
- No non-operational damage such as excessive rust, corrosion, mishandling, torch marks, or fire damage.
- Must be returned on stand that was provided.
- Not previously disassembled
- Housing not visibly cracked, broken, or welded.
- External shaft not cracked, broken, chipped, or bent.

## Partial Credit:

- Housing visibly cracked, broken, or welded.
- External shaft cracked, broken, chipped, or bent.
- Failed non-running core.
- Non-operational damage (mishandling, excessive rust, corrosion, or pitting)

## No Core Refund:

- Unacceptable part number (ex. CAT Classic or non-Caterpillar part).
- Disassembled or not complete.
- Fire damage.
- Unsuccessful attempt to salvage.

## Inspection Tips:

- Non-Operational Damage: If rust can be removed with an emery cloth, the core will be accepted for full credit. Excessive rust, corrosion, or pitting is most likely caused by improper storage and will result in no core credit.
- Fully assembled and complete: No credit will be issued for cores that are returned disassembled. External parts that are missing or damaged will be subject to additional billing at the replacement cost of the component. If the core has been disassembled and reassembled, add charges will apply.

Full Core Credit



Partial Credit



No Core Refund



*Figure 1: Disassembled*



*Figure 2: Non-caterpillar part number*

# Hydraulic Rod Packs

You will receive:

## Full Credit:

- Acceptable part number.
- Fully assembled and complete. Non failed, running core. **\*\*Ask the service department or customer for the reason why the component was replaced.**
- No non-operational damage such as excessive rust, corrosion, mishandling, torch marks, or fire damage.
- Must be returned on stand that was provided.
- Rod not visibly cracked, broken or visibly bent. Bend must be within specifications outlined in [SEBF8072](#).
- Head or piston not damaged or missing.
- Rod eye not visibly cracked or broken.

## Partial Credit:

- Rod visibly cracked, damaged, broken or visibly bent. Bend must be within specifications outlined in [SEBF8072](#).
- Non-operational damage (mishandling, excessive rust, corrosion, or pitting).
- Damage (pitting, scoring) to piston or head.
- Failed, non-running core.

## No Core Refund:

- Unacceptable part number (ex. CAT Classic or non-Caterpillar part).
- Disassembled.
- Fire damage.
- Unsuccessful attempt to salvage.

## Add Charge:

- Core not delivered on proper metal stand



# Pump Drive

You will receive:

## Full Credit:

- Acceptable part number.
- Non-failed, running core with no known internal damage. **\*\*Inspection Tip: Ask customer or service department for reason of replacement.**
- Not visibly cracked, broken, bent, or welded.
- Mounting bolt holes are not worn or elongated.
- Must rotate two full revolutions.
- No non-operational damage such as excessive rust, corrosion, mishandling, torch marks, or fire damage.
- Must be returned on stand that was provided.

## Partial Credit:

- Acceptable part number
- Failed, non-running core.
- Drive group does not rotate two full revolutions.
- Housing visibly cracked, broken, bent, or welded.
- Non-operational damage (mishandling, excessive rust, corrosion).

## No Core Refund:

- Unacceptable part number (ex. CAT Classic or non-Caterpillar part).
- Disassembled or not complete.
- Non-operational damage (Fire damage, unsuccessful attempt to salvage, welding).

**Add Charge:**

- Core not delivered on proper metal stand
- Oil not drained

**Inspection tips:**

- **Rotation Requirement:** Using a strap wrench or other suitable rotation tool, rotate the input shaft to validate that the core is a non-failed, running core. Rotate the input shaft 2 revolutions in one direction. That will achieve a full revolution of the output shaft. During the rotation test, be conscious of internal noise, rubbing, vibration or looseness of parts. All of these examples would be an indication of an internal failure and Damaged Core Refund should be applied.

**Figure 1**

Input shaft to be spun during rotation test

# Radiators

You will receive:

## Full Credit:

- Acceptable part number.
- Fully assembled and complete. Non failed, running core.  
**\*\*Ask the service department or customer for the reason why the component was replaced.**
- No non-operational damage such as excessive rust, corrosion, mishandling, torch marks, or fire damage.
- Must be returned on stand that was provided.
- Drained of all fluids.

## No Core Refund:

- Unacceptable part number (ex. CAT Classic or non-Caterpillar part).
- Disassembled or not complete.
- Fire damage.
- Unsuccessful attempt to salvage.

# Rocker Arms

You will receive:

## Full Credit:

- Acceptable part number.
- Fully assembled and complete.  
**\*\*Ask the service department or customer for the reason why the component was replaced.**
- No non-operational damage such as excessive rust, corrosion, mishandling, torch marks, pitting, or fire damage.
- No cracked or broken forgings

## No Core Refund:

- Unacceptable part number (ex. CAT Classic or non-Caterpillar part).
- Visibly broken or cracking forgings
- Non-operational damage such as excessive rust, corrosion, mishandling, torch marks, pitting, or fire damage.
- Unsuccessful attempts to salvage.



**Figure 1** Full Core Refund  
Fully assembled and complete



**Figure 2** Full Core Refund  
Fully assembled and complete



**Figure 3** Full Core Refund  
Fully assembled and complete



**Figure 4** No Core Refund  
Broken forging

# Starters

You will receive:

## Full Credit:

- Acceptable part number.  
Fully assembled and complete. Non failed, running core. **\*\*Ask the service department or customer for the reason why the component was replaced.**
- No non-operational damage such as excessive rust, corrosion, mishandling, torch marks, or fire damage.
- No cracked or damaged housings.

## Partial Credit:

- Housing cracked or damaged.
- Non-operational damage (mishandling, excessive rust, corrosion, or pitting).

## No Core Refund:

- Unacceptable part number (ex. CAT Classic or non-Caterpillar part).
- Disassembled or not complete.
- Fire damage.
- Unsuccessful attempt to salvage.

# Torque Converter & Transmission

You will receive:

## Full Credit:

- Acceptable part number.
- Fully assembled and complete. Non failed, running core. **\*\*See inspection tips for rotation test. Ask service department or customer for reason why component was replaced.**
- No non-operational damage such as excessive rust, corrosion, mishandling, torch marks, or fire damage.
- Must be returned on stand that was provided.
- Case, housing, splines, shafts and yoke not visibly cracked, broken or welded.
- No damage to mounting surfaces.

## Partial Credit:

- Failed, non-running core. Evidence of bearing, gear or other internal failure. (Use Spin Test).
- Performance problems may indicate a failed unit resulting in a partial core credit. (Ask customer or service department for reason why the component was replaced)
- Case, housing, splines, shafts and yoke visibly cracked, broken or welded.
- Non-operational damage (mishandling, excessive rust, corrosion, or pitting).

## No Core Refund:

- Unacceptable part number (ex. CAT Classic or non-Caterpillar part).
- Disassembled or not complete.
- Fire damage.

- Unsuccessful attempt to salvage.

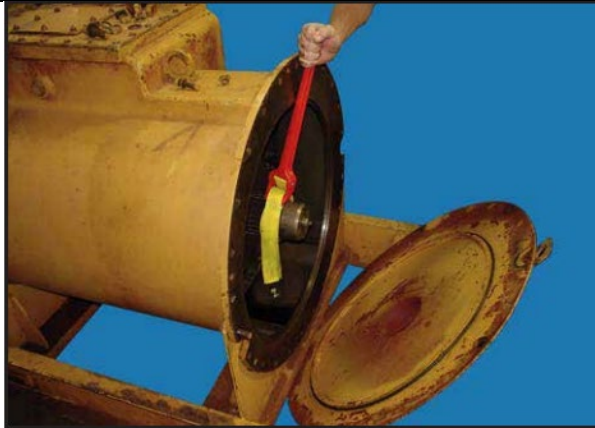


Figure 1: Rotation test example

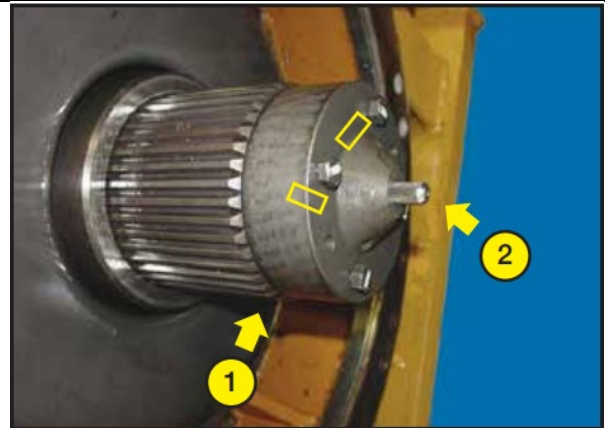


Figure 2: No visible cracks or damage on splines and shaft

## Add Charge:

- Broken or previously welded cases or housing will be subject to additional billing.
- Additional supplied yokes shall be returned with used cores. Add charges will apply for any outstanding yokes.

## Inspection Tips:

- Rotation Requirements: Using a strap wrench or other suitable rotation tool, perform a rotation test to assess that the core is a non-failed, running core (see Figure 7). Listen primarily for noises that would indicate internal failures.

**Torque Converters:** The following inspection may be performed while core is fastened to the metal stand. This will be followed by “Step 1”.

**Step 1** - Rotate output shaft (yoke) two full revolutions in one direction. Unit must rotate freely without noise, rubbing, vibration, or looseness of parts.

**Step 2** - Repeat Step 1 for input end(flywheel pilot).

- Partial Credit - Failed Unit: Cores found to be in non-running condition will be subject to a partial core credit. Evidence of failed bearing, gear, or other internal parts may be seen in the filter or screen in the form of metallic material. A SOS sample may also provide evidence of a failed unit. A failed



- unit will not drive or shift properly in all forward and reverse gears.
- Fully Assembled and Complete: Torque Converters which appear to have salvageable parts removed from them and had non-salvageable parts substituted in their place will be subject to a detailed inspection.
  - Preparing for Shipment: Please ensure that all oil and fluids are drained prior to shipment and the torque converter is securely fastened to its metal shipping stand. Failure to do so could result in fines from the Ministry of Transport or result in Health and Safety concerns

# Traction Motor

You will receive:

## Full Credit:

- Acceptable part number.
- Fully assembled and complete. **\*\*Ask the service department or customer for the reason why the component was replaced.**
- Stator housing is not visibly cracked, broken, bent, or welded.
- Stator windings free of ingrained contaminants that cannot be removed.
- Rotor shaft or splines are not cracked, broken, welded, or excessively worn/stripped.
- Rotor shaft rotates one full revolution freely without internal noise or dragging.
- No non-operational damage such as excessive rust, corrosion, mishandling, torch marks, or fire damage.
- Must be returned on appropriate shipping stand.

## Partial Credit:

- Acceptable part number
- Fully assembled and complete.
- Rotor shaft does not rotate one full revolution freely without internal noise or dragging.
- Stator windings featuring ingrained contaminants that cannot be removed.
- Visual evidence of an unsuccessful attempt to salvage.
- Non-operational damage (excessive rust, mishandling).

## No Core Refund:

- Unacceptable part number (ex. CAT Classic or non-Caterpillar part).
- Disassembled or not complete.
- Stator housing is visibly cracked, broken, or bent.

- Non-operational damage (Fire damage, unsuccessful attempt to salvage, welding).



Figure 1 Full Core Refund  
Rotor shaft support/lock (Traction motor only)



Figure 2 795 Traction Motor Full core Refund  
Properly wrapped and secured to the shipping stand  
(Material added behind Ratchet to avoid damage to wrapping)

# Turbochargers

You will receive:

## Full Credit:

- Acceptable part number.
- Fully assembled and complete. Non failed, running core.  
**\*\*INSPECTION TIP – SHAFT MUST SPIN FREELY & NO DAMAGE TO TURBINE OR COMPRESSOR FINS.**  
**\*\*Ask the service department or customer for the reason why the component was replaced.**
- No non-operational damage such as excessive rust, corrosion, mishandling, torch marks, or fire damage.
- Must be returned on stand that was provided if applicable.

## Partial Credit:

- Housing or turbine wheels damaged from operational failure.
- Non-operational damage (mishandling, excessive rust, corrosion, torch marks or pitting).
- Failed, non-running core.
- Band clamps are loose or missing
- Nozzle ring damaged (Part # 2848281)

## No Core Refund:

- Unacceptable part number (ex. CAT Classic or non-Caterpillar part).
- Disassembled or not complete.
- Fire damage.
- Unsuccessful attempt to salvage.
- Coked or damaged turbine shaft (Part # 2848281)

## Inspection Tips:

- Fully assembled and complete: Band clamps must be tightened prior to shipment to prevent damage to the cartridge. Turbocharger cores disassembled or with loose or missing band clamps will receive PARTIAL CREDIT, provided they meet all other core criteria.
- Housing Damage: Extensive damage to either housing caused by a severe failure of the wheel and shaft which makes the housing non-repairable will be given only a PARTIAL CREDIT. Guidelines to use include severe scoring of the internal housing surface particularly on the compressor side.

### Full Core Refund



Figure 1: Fully assembled and complete



Figure 2: Fully assembled and complete

### No Core Refund



Figure 3: Broken housing resulting from mishandling



Figure 4: Turbocharger damaged by fire



Figure 5: Non-operational damage - broken center housing



Figure 6: Non-operational damage - melted by torch



Figure 7: Non-operational damage - melted by torch

# Water Pumps

You will receive:

## Full Credit:

- Acceptable part number.  
Fully assembled and complete. **\*\*Ask the service department or customer for the reason why the component was replaced.**
- No non-operational damage such as excessive rust, corrosion, mishandling, torch marks, or fire damage.
- Must be returned in the packaging that was provided.
- Housing, pulley, or gear not cracked, broken, or welded.

## Partial Credit:

- Non-operational damage (mishandling, excessive rust, corrosion, torch marks or pitting).

## No Core Refund:

- Unacceptable part number (ex. CAT Classic or non-Caterpillar part).
- Disassembled or not complete.
- Fire damage.
- Unsuccessful attempt to salvage.
- Housing, pulley, or gear is cracked, broken, or welded

# Wheel Groups

You will receive:

## Full Credit:

- Acceptable part number.
- Cracks, dents that are repairable based on the published salvage and reuse guidelines found in [SEBF9406](#) and [SEBF9414](#).
- Salvaged or an attempt to salvage that complies with the published salvage and reuse guidelines outlined in SEBF9406 and SEBF9414 (refer to the Inspection Tips.)
- Must be returned on stand that was provided. **\*\*\*Inspection Tip: Ask customer or service department for reason of replacement.**

## No Core Refund:

- Unacceptable part number (ex. CAT Classic or non-Caterpillar part).
- Cracks, dents which are NOT repairable based on the published salvage and reuse guidelines SEBF9406 and SEBF9414
- Salvaged or an attempt to salvage that does not comply with the published salvage and reuse guidelines outlined in SEBF9406 and SEBF9414 (refer to the Inspection Tips).
- Non-operational damage (unsuccessful attempt to salvage or mishandling
- Flange damage or elongated stud holes.
- For fabricated wheels, previous attempts to salvage in the wrapper band area.

## Add Charge:

- Core not delivered on proper metal stand
- Oil and fluids not drained prior to shipping.

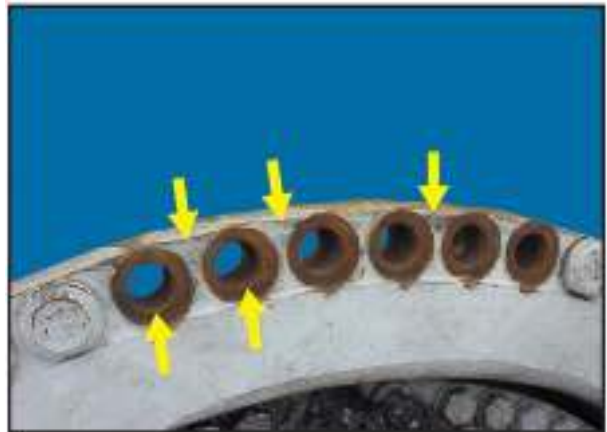


No Core Refund

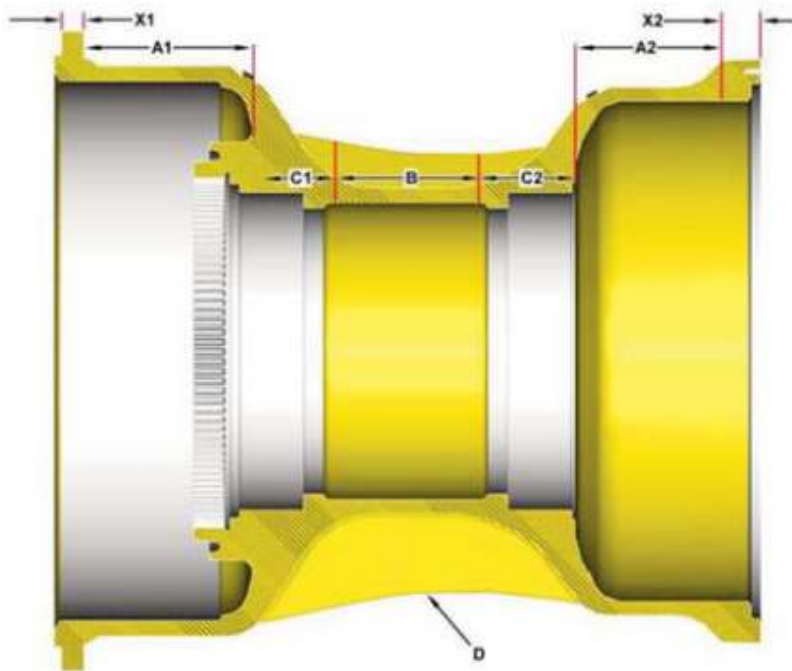


*Figure 1: Flange Damage*

No Core Refund



*Figure 2: Elongated Stud Holes*

**Inspection Tips**


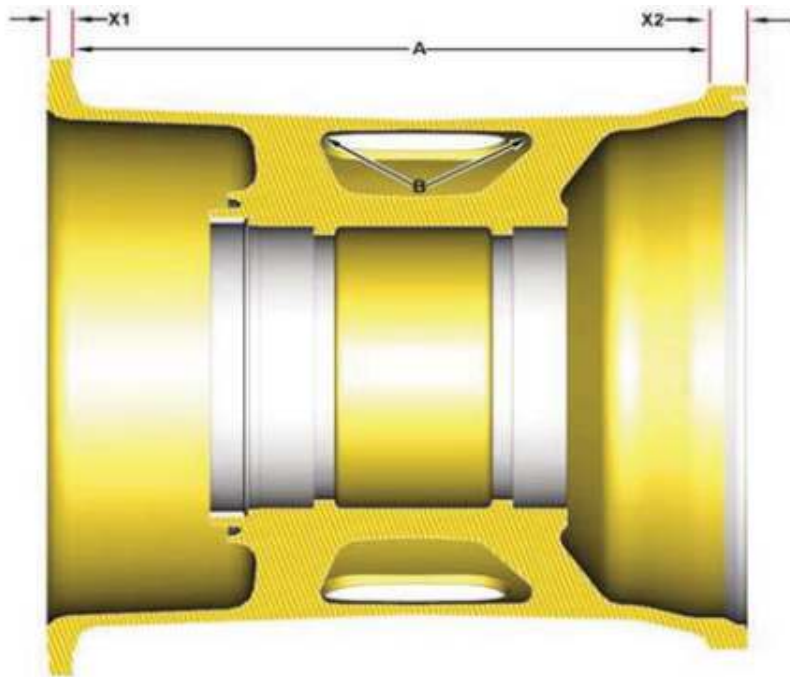
- X1** Inner Flange
- X2** Outer Flange
- A1** Inner Wheel Web
- A2** Outer Wheel Web
- B** Gusset Area
- C1** Inner Radius Area
- C2** Outer Radius Area
- DW** heel Web

**Full Core Refund**

- Maximum crack length of 16 mm from hole to hole, hole to ODoF the flange with a maximum of 3 cracks allowable with a minimum of 4 holes in between cracks in areas X1 and X2.
- Cracks 26.0 mm or less on the “as cast” surface in the (A1) or (A2) areas.
- Cracks 16 mm or less on the (A1) or (A2) machined surfaces.
- Maximum crack length of 26 mm and/or maximum grind depth of 2.5 mm allowed in areas A1, A2, B, and D, otherwise maximum grind depth of 6 mm allowed in area C1, C2

**No Core Refund**

- welding or grinding in X1 & X2 areas.
- Cracked to the point of rupture on any part of the wheel.
- Flange section broken.
- Cracks from holes to flange radius.
- Cracks longer than 16 mm in the X1 & X2 areas.
- Cracks longer than 26 mm in areas A1, A2, B, C1, C2, and D and/or grind depth larger than 2.5 mm in areas A1, A2, B, and D and/or grind depth larger than 6 mm in area C1, C2.



**X1** Inner Flange  
**X2** Outer Flange  
**AW** heel Web  
**B** Gusset Radius

### Full Core Refund

- Maximum crack length of 16 mm from hole to hole and hole to OD of the flange with a maximum of 3 cracks allowable with a minimum of 4 holes in between cracks in areas X1 and X2.
- Maximum crack length of 26 mm and/or maximum grind depth of 2 mm in area A.
- No crack or previous salvage attempt in gusset area (B) can be deeper than 35 mm.

### No Core Refund

- No welding or grinding in X1 & X2 areas.
- Cracked to the point of rupture on any part of the wheel.
- Flange section broken.
- Cracks from holes to flange radius.
- Cracks longer than 16 mm in the X1 & X2 areas.
- Cracks in gusset area (B) that are deeper than 35.0 mm.
- Cracks longer than 26 mm in area A and/or grind depth larger than 2 mm in area A